

# Directly mounted CAN controls

## Product documentation

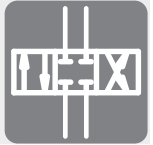

Proportional directional spool valve type PSL and PSV (series connection)  
Proportional directional spool valve type PSLF and PSVF (manifold mounting)

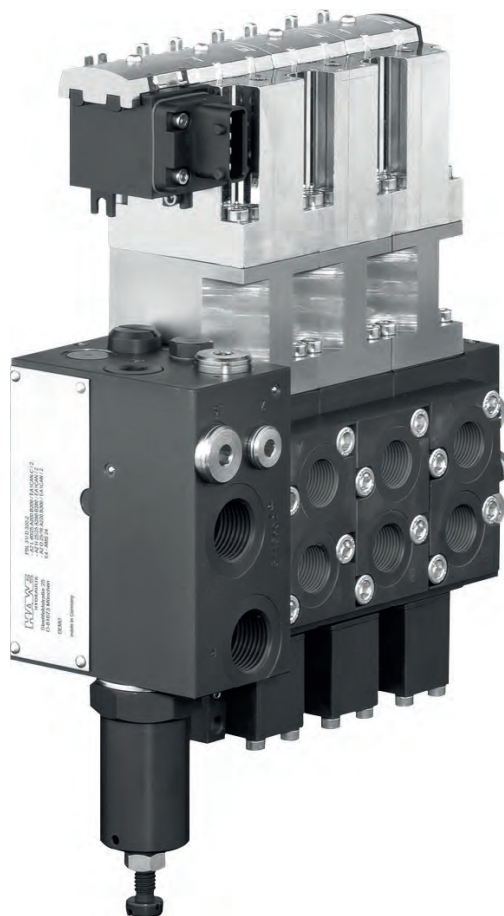

© by HAWE Hydraulik SE.

The forwarding and reproduction of this document, as well as the use and communication of its contents, are forbidden unless expressly permitted.

Any breach or infringement will result in liability for damages.

All rights reserved concerning patent or utility model application.

## Contents

<b>1</b>	<b>Overview of directly mounted CAN controls for proportional directional spool valves.....</b>	<b>4</b>
<b>2</b>	<b>Available versions, main data.....</b>	<b>5</b>
2.1	Order coding, structure.....	5
2.1.1	Combination options.....	6
<b>3</b>	<b>Parameters.....</b>	<b>7</b>
3.1	General parameters.....	7
3.2	Electrical parameters.....	7
3.3	Communication.....	7
3.4	Acceptance tests and environmental tests.....	8
3.5	Electrical connection.....	8
<b>4</b>	<b>Dimensions.....</b>	<b>9</b>
4.1	Actuation add-on.....	9
4.2	Structure of valve bank (series connection) – example.....	11
4.3	Structure of valve bank (manifold mounting) – example.....	12
<b>5</b>	<b>Assembly, operation and maintenance recommendations.....</b>	<b>13</b>
5.1	Intended application.....	13
5.2	Operating instructions.....	14
5.3	Maintenance information.....	15
5.4	Safety instructions.....	15
5.5	Assembly and installation instructions.....	16
5.6	CAN bus control unit.....	17
5.7	Structure of the CAN actuation head.....	19
5.8	CAN starter set.....	19

# 1 Overview of directly mounted CAN controls for proportional directional spool valves

Proportional directional spool valve banks are used to control the direction of movement and the infinite adjustment of the movement speed of the hydraulic consumers independent of the load. This allows multiple consumers to be run at the same time and independently of each other at different speeds and pressures, as long as the sum of the partial flow rates required for this is covered by the total delivery flow on the pump side. The electrical connection between the valve sections is via internal cable connections (power supply and CAN bus).

## Features and benefits:

- Simple wiring
- In-built displacement transducer
- Calibrated at the factory ( $i_{min}$ ,  $i_{max}$ , etc.)
- Configurable valve characteristics (linearisation, precision control ranges etc.)
- Adjustable ramps
- Increased response characteristics
- Ability to limit maximum flow rate
- Diagnostic capability (fault detection, spool position)

## Intended applications:

- Cranes
- Hydraulic steering systems
- Construction machines
- Lifting devices
- Machines for forestry purposes
- Municipal trucks

## Versions:

- Actuation option for sizes 2, 3 and 5 (series connection)
- Actuation option for size 3 and 7 (manifold mounting)

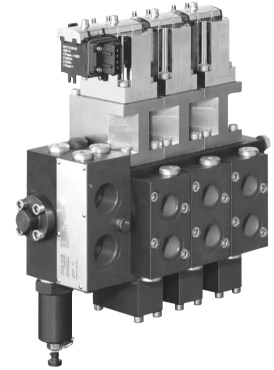

*Valve bank in series connection*

## 2 Available versions, main data

### 2.1 Order coding, structure

Order coding example:

PSV 31/D 170-2	-A 2 J 25/25	/EA /EA /EA	<b>CAN-C</b> CAN CAN-E	/2 /2 /2		-E 4	<b>-AMP</b>
							Connector Table 3 Connectors
			<b>CAN actuation add-on</b>				Table 2 CAN actuation add-on
		<b>Electrical actuation</b>					Table 1 Electrical actuation

The type codings in bold are described in this document. For all other details, please see [D 7700-2](#), [D 7700-3](#), [D 7700-5](#), [D 7700-3F](#) and [D 7700-7F](#)

**Table 1 Electrical actuation**

Marking	Description
<b>EI</b>	Electro-hydraulic
<b>EA</b>	Combined with manual operation

**Table 2 CAN actuation add-on**

At least one connector (marking CAN-C or CAN-T) required on the first or last valve section.  
When using a connector on the valve battery, an end plate (CAN-E) is required on the opposite valve section.

Marking	Description
<b>CAN</b>	CAN actuation head (all valve sections)
<b>CAN-C</b>	CAN actuation head with connection base (on the first and/or last valve section)
<b>CAN-T</b>	CAN actuation head with connection base and integrated 120 Ω terminal resistor (on the first and/or last valve section)
<b>CAN-E</b>	CAN actuation head with end plate
<b>CAN-CC</b>	CAN actuation head with connection bases on the left and right-hand side (only possible with individual CAN actuation head)
<b>CAN-TT</b>	CAN actuation head with connection bases and integrated terminal resistors on the left and right-hand side (only possible with individual CAN actuation head)

For valve batteries with just one valve section with directly mounted CAN controls and a connector, the position of the connector must be defined.

L = left, connector in the direction of the connection block  
R = right, connector in the direction of the end plate

**Table 3 Connectors**

Marking	Description	Appropriate connector
AMP	4-pin connector, with protective circuit	TE 282192-1
AMS	4-pin connector, with protective circuit	TE 1-967059-1
DT	4-pin connector, with protective circuit	TE DEUTSCH DT06-4S

For examples of combination options for different connection bases, see [Chapter 2.1.1, "Combination options"](#)

## 2.1.1 Combination options

### Combination options (examples)

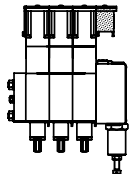
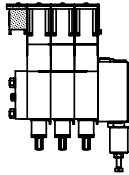
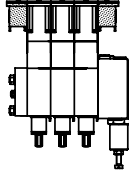
Description	Description	View
CAN-C - CAN - ... - CAN-E	Connection base on first valve section	
CAN-T - CAN - ... - CAN-E	Connection base with terminal resistor on first valve section	
CAN-E - CAN - ... - CAN-C	Connection base on last valve section	
CAN-C - CAN - ... - CAN-C	Connection base on first and last valve section	

## 3 Parameters

### 3.1 General parameters

#### General information

Material	Actuation add-on EI CAN. nickel-plated
Installation position	As desired
Connection	According to type coding, see <a href="#">D 7700-2</a> , <a href="#">D 7700-3</a> , <a href="#">D 7700-5</a> , <a href="#">D 7700-3F</a> , <a href="#">D 7700-7F</a>
Ambient temperature	Approx. -40 to +80°C
Weight	<b>Actuation add-on EICAN</b> ▪ + 0.3 kg

### 3.2 Electrical parameters

Operating voltage $U_B$	10 to 30 V DC
Max. operating current	10 A (CAN connection base)
Current consumption $I_V$	Max. 800 mA at $U_B = 24$ V DC (per valve section) Max. 1.5 A at $U_B = 12$ V DC (per valve section)

### 3.3 Communication

CAN protocol	CANopen, J 1939
CAN bit rate	10 ... 1000 kbit/s
CAN-ID	1 ... 127



#### Note

For further information see [B 7700 CAN Manual](#)

### 3.4 Acceptance tests and environmental tests

EMC	E1-ECE regulation no. 10 revision 3 - 11 July 2008		
Protection class IP 67	DIN 40050-9		
Shocks	EN 60068-2-29	25 g, 3 axes	
Vibrations	DIN EN 60068-2-6	5 ... 500 Hz, 2 mm amplitude (5 ... 25 Hz), 5.0 g (25 ... 500 Hz), 3 axes	
Temperature change	DIN EN 60068-2-14	-40°C - +85°C (1.5 K/min)	
Coldness	DIN EN 60068-2-1	-40°C	
Damp heat	DIN EN 60068-2-30	95% air humidity, 24 h	
Dry heat	DIN EN 60068-2-2	85°C, 16 h	

### 3.5 Electrical connection

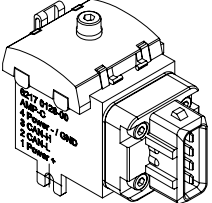
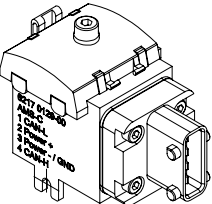
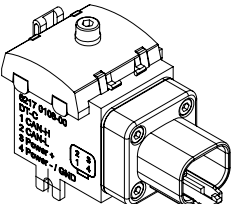
Marking	Description	Terminal assignment	
AMP	4-pin Connector with protective circuit	1: Power + 2: CAN-L 3: CAN-H 4: Power - /GND	
AMS	4-pin Connector with protective circuit	1: CAN-L 2: Power + 3: Power - /GND 4: CAN-H	
DT	4-pin Connector with protective circuit	1: CAN-H 2: CAN-L 3: Power + 4: Power - /GND	

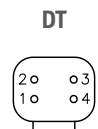
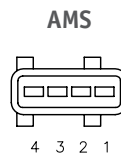
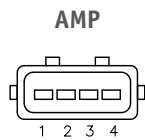



## 4 Dimensions

All dimensions in mm, subject to change.

### 4.1 Actuation add-on

Actuation add-on **CAN-C**, **CAN-T** and **CAN**

Size 2  
(series connection)

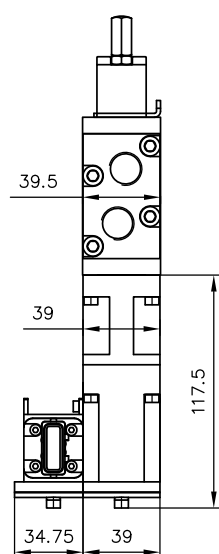

Size 3  
(series connection)

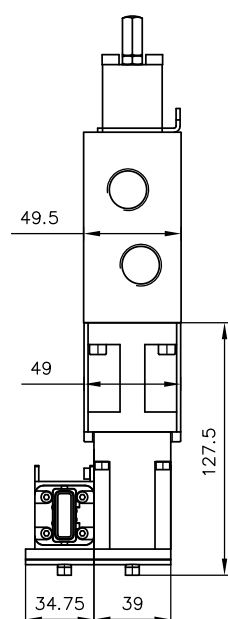

Size 5  
(series connection)

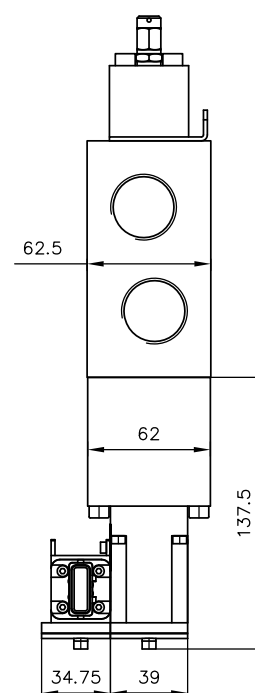

Size 3  
(manifold mounting)

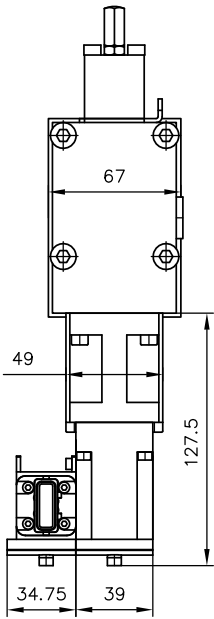

Size 7  
(manifold mounting)

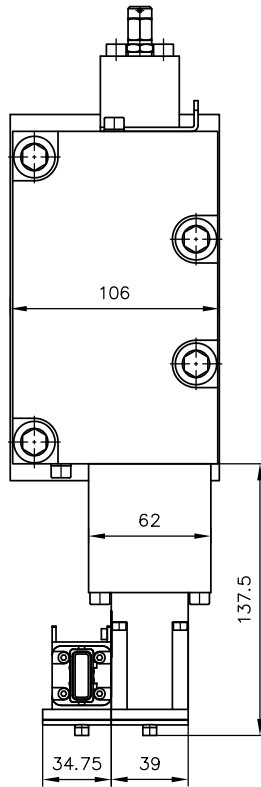

## 4.2 Structure of valve bank (series connection) – example

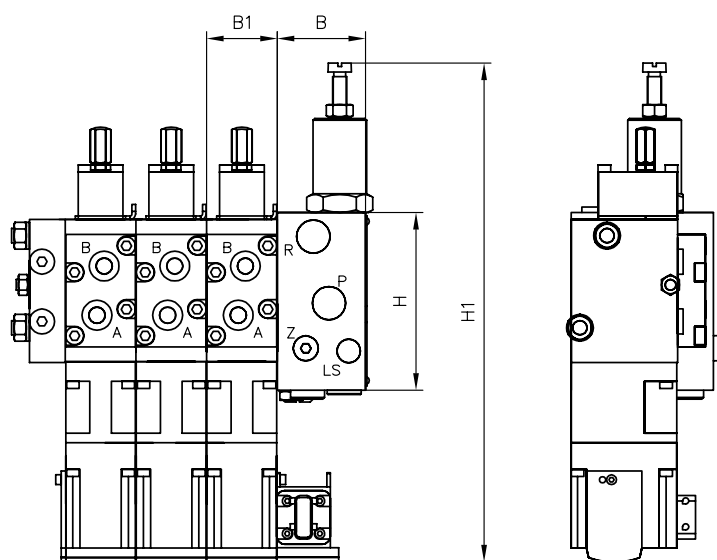
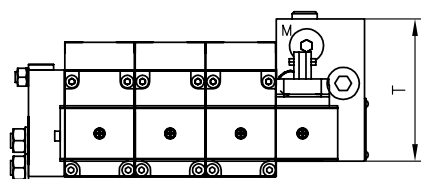

Marking	B	B1	H	H1	T
PSL/PSV size 2	49.5	39.5	99.5	279	79.5
PSL/PSV size 3	49.8	49.5	110 to 123	294	80
PSL/PSV size 5	99.5	62.5	137.5	314.5	100

4.3 Structure of valve bank (manifold mounting) – example

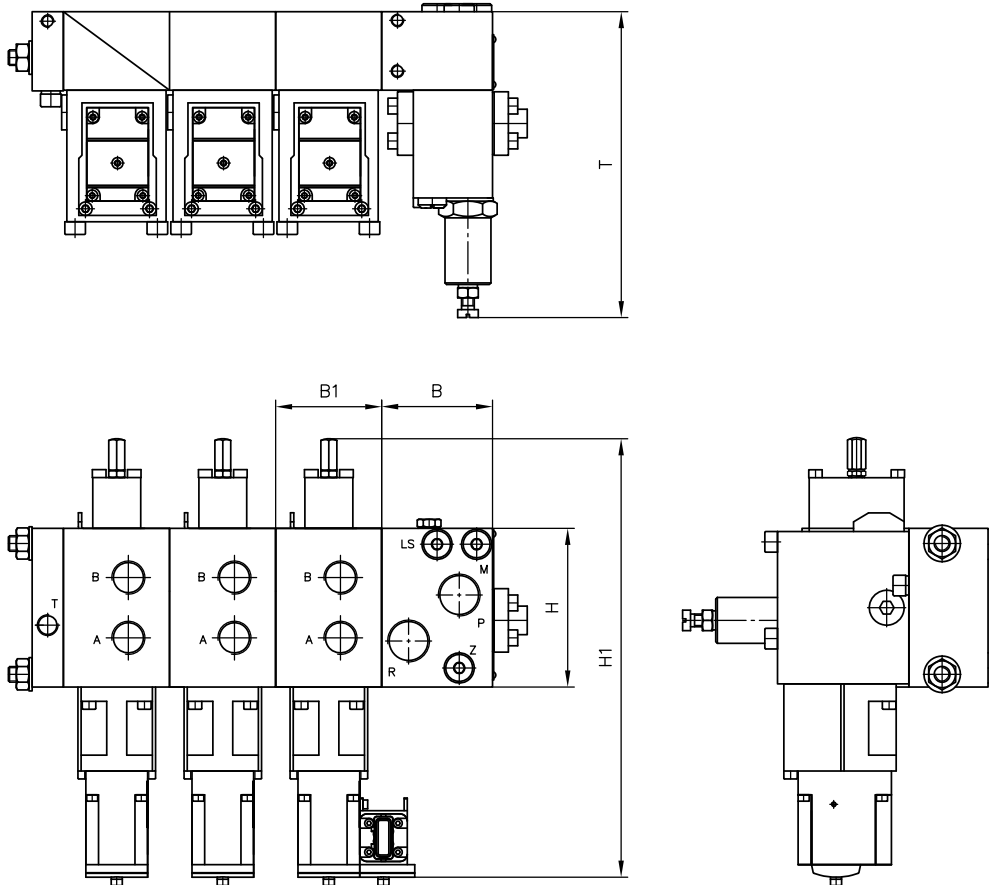

**Marking**

Marking	B	B1	H	H1	T
PSLF/PSVF size 3	70	67	100	276.5	194
PSLF/PSVF size 7	99	106	185	363	194

**5****Assembly, operation and maintenance recommendations****5.1 Intended application**

This valve is intended exclusively for hydraulic applications (fluid engineering). The valve meets high technical safety standards and regulations for fluid and electrical engineering.

The user must observe the safety measures and warnings in this documentation.

Essential requirements for the product to function correctly and safely:

- All information in this documentation must be observed. This applies in particular to all safety measures and warnings.
- The product must only be assembled and put into operation by qualified personnel.
- The product must only be operated within the specified technical parameters. The technical parameters are described in detail in this documentation.
- The operating and maintenance manual of the specific complete system must also always be observed.

If the product can no longer be operated safely:

Remove the product from operation and mark it accordingly. It is then not permitted to continue using or operating the product.

## 5.2 Operating instructions

### Product configuration and setting the pressure and flow rate

The statements and technical parameters in this documentation must be strictly observed.  
The instructions for the complete technical system must also always be followed.



#### Note

- Read the documentation carefully before usage.
- The documentation must be accessible to the operating and maintenance staff at all times.
- Keep documentation up to date after every addition or update.



#### Caution

##### **Risk of injury on overloading components due to incorrect pressure settings!**

Risk of minor injury.

- Always monitor the pressure gauge when setting and changing the pressure.

### Purity and filtering of the hydraulic fluid

Fine contamination can significantly impair the function of a hydraulic power pack. Contamination can cause irreparable damage.

Examples of fine contamination include:

- Metal chips
- Rubber particles from hoses and seals
- Dirt due to assembly and maintenance
- Mechanical debris
- Chemical ageing of the hydraulic fluid



#### Note

Fresh hydraulic fluid from the drum does not always have the highest degree of purity. Under some circumstances the fresh hydraulic fluid must be filtered before use.

Pay attention to the cleanliness level of the hydraulic fluid in order to maintain faultless operation.

### 5.3 Maintenance information

This product is largely maintenance-free.

Conduct a visual inspection at regular intervals, but at least once per year, to check if the hydraulic connections are damaged. If external leakages are found, shut down and repair the system.

Clean the device surface of dust deposits and dirt at regular intervals, but at least once per year.

### 5.4 Safety instructions

All installation, set-up, maintenance and repairs must be performed by authorised, qualified and trained staff. The use of this product beyond the specified performance limits, operation with non-specified fluids and/or use of non-genuine spare parts will invalidate the warranty.

The general operating manual for the assembly, commissioning and maintenance of oil-hydraulic components and systems must be observed.

### Transportation and storage

Analogous to hydraulic components, proper storage and suitable packaging for the product must be ensured. There are no particular requirements resulting from the combination of control electronics and valve.

**Note**

The plastic connector base is mechanically limited in terms of load capacity and is unsuitable for use as a handle!

## 5.5 Assembly and installation instructions

### Mounting

The valve bank must be mounted free from distortion to the machine chassis or frame. It is recommended to mount using three screws and to use elastic spacers between the block and the frame.

### Installation

To ensure safe operation of the PSl/PSV CAN valve nodes and to avoid shortening the lifetime of the product through improper operating conditions, the following instructions must be observed:

- Avoid installing the valves near machine parts and assemblies that produce lots of heat (e.g. exhaust).
- Radio equipment must be a sufficient distance away.
- An emergency shut-off must be provided for the power supply. The emergency stop switch must be installed on the machine (vehicle) where it is easily accessible by the machine/system operator. The machine (vehicle) manufacturer must ensure that a safe state is produced when the emergency stop switch is actuated.
- One of the mechanisms supported by the device to protect against bus interruptions (node guarding, heartbeat) must be used.
- The power feed must be dimensioned and fused in accordance with the maximum possible current consumption. A maximum current of approx. 1.5 A at 12 V and 0.8 A at 24 V supply must be set per valve section.
- Earth lines must be dimensioned in accordance with the maximum currents flowing to them. The reference potential for all CAN bus nodes connected to a single line should vary as little as possible from device to device and be identical with the earth connection for the power supply.
- All valve nodes must be unplugged in the event of electric welding work.
- Connectors used to connect the valve battery must be properly secured against water ingress by applying all necessary seals.
- Bus lines suitable for CAN bus networks must be used. Lines should ideally be twisted and screened. The surge impedance must be approx. 120  $\Omega$ .
- There must be 120  $\Omega$  terminating resistors at both ends of the CAN bus network.
- Valve electronics and the associated magnet block are screwed together and sealed. They must not be separated from each other. When replacing the valve spool or the spool block, ensure correct reassembly and sealing.
- Maintain a sufficient distance from sources of magnetic fields, e.g. strong permanent magnets, eddy-current brakes etc. (> 0.5 m).
- If the bus and supply line needs to be removed from individual valve modules during installation or servicing, new cables must be used for reassembly and the sealing elements and end caps must be correctly installed. Cables are available as spare parts.

The following must also be observed during operation:

- The proper operation of the control unit can be ensured only within a temperature range of -40°C to +85°C.
- If the device detects internal overheating, restricted operation (i.e. at reduced power) is possible within a certain temperature range.
- Increased surface temperature and burning on contact can particularly occur at the magnet block.
- The power supply must be within the specified working range. High or constant deviation can damage the electronics.



## 5.6 CAN bus control unit

### General information

The CAN bus (Controller Area Network) is an asynchronous, serial bus system requiring just two wires for data transmission. According to ISO 11898-2 (High-Speed Medium Access Unit), twisted-pair cables with a surge impedance of 108 to 132  $\Omega$  are recommended as a bus medium.

Conventional data transmission formats are protocols CANopen 2.0 A & B and J1939, based on 11 Bit or 29 Bit address data.

### Design of CAN bus systems

In general, a linear network topology should be aimed for and spur lines should be avoided. If this is not possible, the maximum spur line lengths in accordance with Table 1 apply.

Short bus lines with a low EMC load do not require the CAN line to be screened. For major network expansion or environments with EMC loads, screening of the CAN line with corresponding earthing should be applied.

Twisted bus cables are a compromise solution that are easier to implement in cable harnesses. There must not be a shift in potential between the individual CAN nodes.

Device earths for all CAN node devices must be sufficiently dimensioned and should be brought together at a common neutral point. If a CAN PSL/PSV valve bank is operated in the passage, i.e. it has two contact bases and is looped into the bus line, the maximum current carrying capacity of the contact bases must be observed. If necessary, bus nodes with a high current consumption should not be supplied via the valve battery, but have their own power supply. A max. current of 10 A must not be exceeded.

Transfer rate	Bus length	Max. length of spur line
100 kbit/s	600 m	25 m
125 kbit/s	500 m	20 m
250 kbit/s	250 m	10 m
500 kbit/s	100 m	5 m
1,000 kbit/s	< 20 m	1 m

The power supply and the CAN bus are passed from section to section by means of an internal cable connection. The connection cable contains four wires: power supply (uBat, GND) and CAN bus (CAN high, CAN low). The recommended terminating resistor is not necessary for short spur lines.

### Plug-and-Play slave valve nodes with PLVC

A Plug-and-Play configuration can be used for CAN nodes to provide an extended output level with the HAWE control units of type PLVC. Requiring no communication within the user program, these external valve outputs are managed by the PLVC operating system and can be used in a way analogous to existing valve outputs.

Plug-and-Play functionality requires merely the following requirements for the address specification: the external valves controlled via CAN bus must be assigned to CAN node IDs from 32 onwards; all other data traffic and the associated monitoring and safety functions are assumed by the PLVC.

Single valves are addressed with sequential indices from 2000 onwards. The indices of twin valves are calculated based on  $2000 + 2 \cdot n$ , where  $n$  is the number of the section.

Section number n	PLVC ID	Node ID	Target COB ID	Actual COB ID
1	2000	32	0x220	0x1A0
2	2002	34	0x222	0x1A2
3	2004	36	0x224	0x1A4
4	2006	38	0x226	0x1A6
5	2008	40	0x228	0x1A8
6	2010	42	0x22A	0x1AA
7	2012	44	0x22C	0x1AC
8	2014	46	0x22E	0x1AE
9	2016	48	0x230	0x1B0
10	2018	50	0x232	0x1B2

## 5.7 Structure of the CAN actuation head

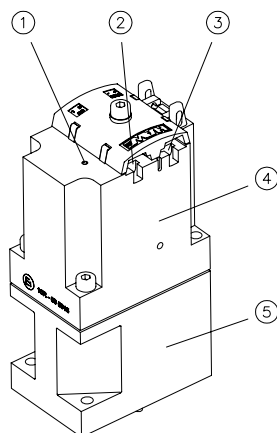

1	Status LED
2	Data line (CAN-L, CAN-H)
3	Power supply (+/-)
4	Electronics module
5	Actuation unit

## 5.8 CAN starter set

The CAN starter set enables communication and functionality of CAN valves from a desk, i.e. without a fully functioning complete hydraulic system.

With the CAN starter set, a PC can be used as a partner for the valve (point-to-point connection to the CAN dongle). However, complete bus system simulations containing several bus nodes can also be run.

### Scope of delivery

- Electronics module including actuating solenoid
- 4-pin AMP mating connector for adaptation to D-Sub and 4-mm spring connector for power supply
- Data carrier with the HAWE CanNodeTool and drivers

Order coding and item numbers:

- PSX-CAN starter kit: 3405 4200-00
- PEAK CAN USB dongle: 6219 2001-00

A power supply unit for the electric power supply is not included in the scope of delivery. This is required for operation (e.g. 24 V, 1 A).

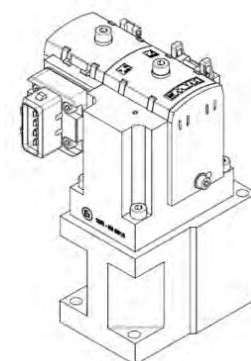

## Further information

### Additional versions

- Proportional directional spool valve, type PSL and PSV size 2: D 7700-2
- Proportional directional spool valve, type PSL, PSM and PSV size 3: D 7700-3
- Proportional directional spool valve, type PSL, PSM and PSV size 5: D 7700-5
- Proportional directional spool valve type PSLF, PSVF and SLF size 3: D 7700-3F
- Proportional directional spool valve banks type PSLF and PSVF size 7: D 7700-7F
- Programmable logic valve control type PLVC 8: D 7845 M
- CAN node type CAN-IO: D 7845-IO 14
- Electronic amplifier type EV2S: D 7818/1